



## Features and Benefits

- Blend the thickest ingredients to a perfect consistency every time with a 3.5 HP\* high performance motor
- Customize 4 reprogrammable beverage stations to save time – Just choose a program and walk away
- A built-in feedback circuit keeps RPMs high, and your customers from waiting
- Create your ideal frozen drink or smoothie with the adjustable speed controls
- Easy-to-clean electronic membrane keypad with backlit LCD screen
- Dual pulse functions allows you to add additional ingredients or restore settled drinks
- Silence your competition with the unbreakable polycarbonate sound enclosure
- Limited Three Year Motor and Two Year Parts and Labor Warranty



\*Peak input HP



Heavy-Duty 3.5 HP\* • *MX1500XTP*



# Xtreme Hi-Power Blender Series MX1500XTP



## Specifications

Item	Electrical	Listings	RPM (bare motor)	Dimensions (H" x W" x D")	Warranty
MX1500XTP	120 Volt, 13 Amp, 50/60 Hz	ETL,NSF	45,000	19.5"x9"x9.5"	Limited 3 Year Motor and 2 Year Parts and Labor

## Ordering Information

Description	Catalog #	Std Pkg.	Ship Wt. (lbs.)	Cubic Feet	UPC Code
Xtreme Hi-Power Blender with 48 oz. Polycarbonate Container	MX1500XTP	1	20 lbs.	0.92	040072006791
48 oz. Polycarbonate Container	CAC93	1	3.5 lbs.	0.33	040072004575
Sound Enclosure for Xtreme Series 48 oz. Containers	SE500	1	5 lbs.	0.95	040072007668

**MX1500XTP**

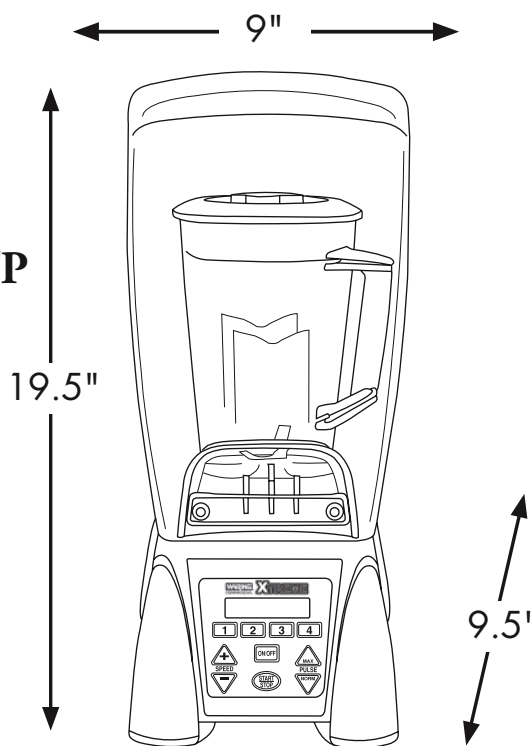

To order Cappuccine products or Waring Commercial Xtreme Blenders:  
1-800-511-3127